

Different Methods Preventing Interactions Problems in Hydraulic Systems

L. Borello, G. Villero, M. D. L. Dalla Vedova

matteo.dallavedova@polito.it, matteodv@yahoo.it – DIMEAS – Politecnico di Torino

Abstract— The design of an airplane hydraulic system concerns the sizing of pipes, pumps and related supply pressure regulation devices. The design of system and subsystems must be performed in an integrated form: in fact different configuration choices regarding each subsystem can appreciably affect the pumps sizing and the system stability. The work highlights the interactions between the design choices concerning both the generation/power regulation and the users in all the aspects important for the operation of the complete system outlining the design of a defined hydraulic system of an airplane. To this end the dynamic simulation models (with associated calculation programs) capable of analyzing the behavior of the complete system have been made; employing it a series of investigations was carried out, aiming to analyze the dynamic behavior of different configurations of the system in similar operating conditions. Particularly, the present work regards the comparison between two different methods/devices capable of preventing major interactions by limiting the actuation speed in aiding load conditions. The above mentioned methods concerns the implementation of a ramp generator in the control law of the critical users or the employment of control servovalves having a reduced spool stroke acting in the aiding load conditions. In conclusion, the paper compares the advantages and shortcomings of the two solutions (reduced spool stroke and ramp generator); as it is usual in these cases, the cheaper solution is not necessarily the best one, in terms of actuation rate control capability. The present work focuses all the considerations regarding the design activities.

Index Terms— aircraft hydraulic system, power regulation, users interaction.

I. INTRODUCTION

The design of an airplane hydraulic system concerns the sizing of pipes, pumps and related supply pressure regulation devices. The design parameters are obtained from the subsystems workload diagrams, taking into account the flight portion in which each subsystem works, the maximum required flow rate and the angular rate of the pumps connected to their own source.

These diagrams give, in each flight portion, the maximum flow required by the subsystems and consequently requested to the system pumps, necessarily of volumetric type. They provide a flow proportional to their displacement so as to their angular rate and slightly decreasing with the prevalence imposed by the system. From the previous considerations the minimum value of the displacement requested to the pump in order to properly move the assigned subsystems can be obtained.

In conditions of reduced flow to the subsystems, a suitable device must adjust the supply pressure, otherwise growing (decreasing flow) or dropping (increasing flow) very rapidly and intensely (volumetric pumps). In particular, it can be noted that the system and subsystems design should be studied in an integrated form: in fact different configurations regarding each subsystem can greatly affect the pumps sizing. Suffice it, for example, to remind that in a flap command the control logic or the reversibility or irreversibility of the final actuators appreciably affects the actuation rate, particularly in aiding load conditions (retraction, so absence of supplied mechanical power) with consequent different values of requested flow rate. It is also convenient to consider some types of limitation in the contemporary operations of the subsystems in every flight condition; it can be performed studying appropriate actuation sequences or actuation rate limitations, if they do not affect the safety levels of the aircraft mission.

II. WORK PURPOSES

The present work, starting from the results described in 1, reminds the interactions between the design choices concerning both the generation/power regulation (pumps and regulating devices) and the subsystems operations. The mentioned interactions, particularly regard the eventual occasional case in which one or more large users are contemporarily actuated in aiding load conditions, so requiring very high hydraulic flow to the system pumps; if these are not able to perform the required flow, the system supply pressure drops to an improper value, so compromising the correct actuation abilities of the primary control system eventually actuated in opposing load condition. The aim of the work is the comparison between two different methods/devices capable of preventing the above mentioned troubles by limiting the actuation speed in aiding load conditions. Two alternative methods are here considered:

- implementation of a ramp generator in the control law of the critical users;
- employment of control servovalves having a limited spool stroke acting in the aiding load conditions.

In order to perform the comparison, the authors consider the hypothetical design of an aircraft hydraulic system equipped with three subsystems of different characteristics and dimensions, as defined by a complete series of operational requirements reported in literature [1-4].

III. SYSTEM LAYOUT

The design of a hydraulic system is based on the requirements which must be met by the subsystems to be connected; the subsystems conceptual design is the result of this activity, which is followed by the definition of the entire hydraulic system.

This conceptual design must be followed by the definition of the various subsystems and controlling devices, in order to meet the requirements concerning both stationary and dynamic conditions. The present work analyzes, as an example, a hydraulic system intended to supply one primary and two secondary flight controls, being this choice, in its simplicity, significant of all the typical problems of interactions between subsystems that may arise in a system more realistically equipped with a high number of subsystems.

The considered system is composed of a fixed displacement pump equipped with a supply pressure controlling and stabilizing device, based on an accumulator and on a pressure control valve. The three subsystems consist of position servomechanisms with servo-valve, cylinder or hydraulic motor, motion transmission and related position control loop (Fig.1).

The work analyzes the case of a military transport aircraft equipped with:

- longitudinal primary hydraulic flight control (USER 1);
- secondary hydraulic flap control (USER 2);
- rear loading ramp door hydraulic actuator (USER 3)

performing an airdrop operation in which a simultaneous actuation of the three aforementioned users may be required.

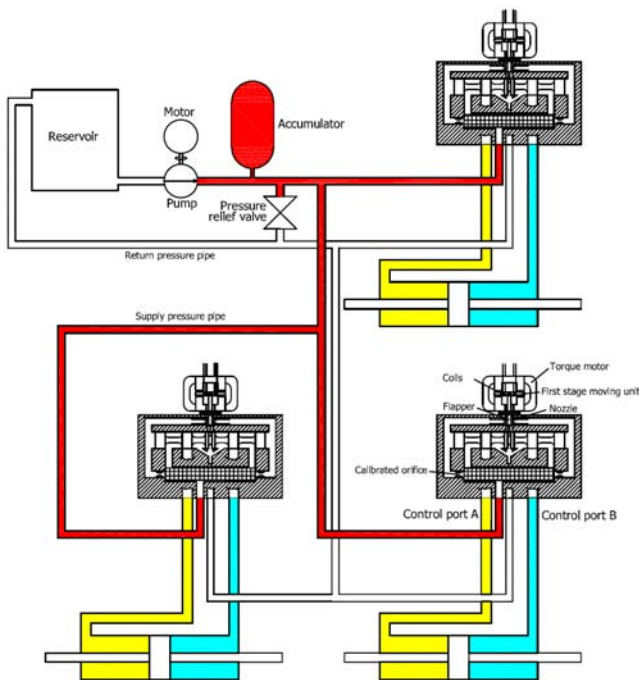

Figure 1. Schematic of the hydraulic system and related users.

IV. CONSIDERED NUMERICAL MODEL

Figures 2, 3 and 4 represent dynamic models, corresponding mathematical algorithms and simulation programs in form of block diagrams regarding:

- user 1 (Fig. 2),
- users 2 or 3 (Fig. 3),
- power generation and control system (Fig. 4).

As in Fig. 2, the error resulting from the comparison between the commanded θ_C and effective θ_j positions is processed, as regards the user 1, through a logic of the proportional (G_{AP}) - integrative (G_{AI}) - derivative (G_{AD}) type equipped with a limiter at the integrator output (e_{IM}) to obtain the driving current through the servovalve first stage torque motor; this, by the torque motor gain G_M , provides the torque acting on the valve first stage which, net of the feedback effect (K_{SF}) coming from the second stage position X_S , gives the first stage position X_F (limited within the ends of travel X_{FM}) according to a second order dynamic characterized by the first stage elastic hinge stiffness K_F , by the circular frequency σ_{nF} and by its damping ratio ζ_F . The first stage position, operated through its flow gain G_{QF} and the area of the second stage end faces A_{SV} , gives the second stage speed which, by a time integration, identifies the position (limited within the ends of travel X_{SM}). From this, through the second stage pressure gain and the effects of the differential pressure saturation, is obtained, net of the pressure drops (depending on the ratio G_{PQ} between the valve second stage pressure to flow gains) due to the total flow Q_j requested by the hydraulic piston, the differential pressure P_{12} actually acting on the latter. It identifies the leakage flow through the proper coefficient C_{LK} and, by piston area A_j and mass M_j , net of load F_R , viscous (coefficient C_j) and dry friction [5-6], gives its acceleration ($d^2\theta_j/dt^2$); the latter, through a time integration, gives the speed ($d\theta_j/dt$) which defines the values of viscous friction, dry friction and jack working flow. The last, added to the leakage flow, gives the pressure drop through the valve passageways. The speed integration gives the actual position of the controlled element (θ_j) which is closed in loop on the command, so performing the position error value. With regard to 2 and 3 users (Fig. 3) the same considerations apply with the exception of the control logic: in fact the current driving the servovalve is obtained by the position error through a proportional law with speed servo loop instead of a PID type, and is equipped with a ramp generator input command. As reported in Fig. 4, the flow rate Q_P supplied by the pump minus the sum of the flow absorbed by users (Q_{S1}, Q_{S2}, Q_{S3}), internal pump leakage flow according to the coefficient C_{LKP} and flow Q_{RV} drained towards the tank through the pressure relief valve, acts on pump and lines hydraulic capacity C_P and on accumulator capacity C_A by varying the supply pressure P_S limited to the hydraulic fluid vapor pressure P_V ; by the difference between the P_S pressure and the return pressure P_R the differential pressure P_{SR} that the plant delivers to the users is obtained.

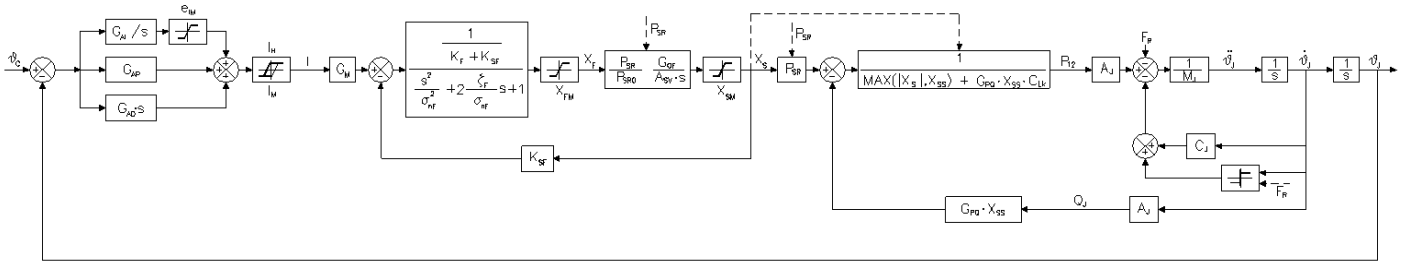

Figure 2. USER 1 block diagram.

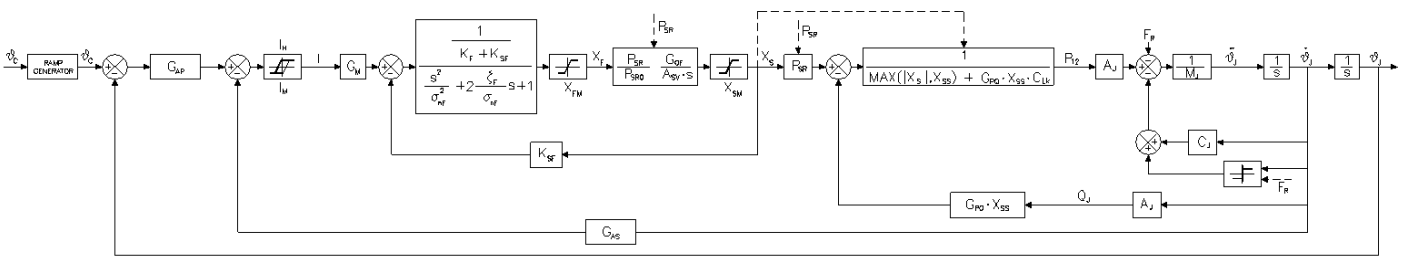

Figure 3. USER 2 and 3 block diagram.

The last acts on the pressure relief valve modeled as a first order subsystem (the moving element inertia can be considered slightly influent on its dynamic behavior) having τ as time constant, $1/k_{ARV}$ as static gain, x_{RV0} as spring compression in preload condition; the result is the pressure relief valve flapper displacement X_{RV} and, as a consequence, its flow area through the coefficient $C_D \cdot A_{xRV}$.

The last, together with P_{SR} , by means of the flow equation through an orifice, gives the Q_{RV} crossing the pressure relief valve, reported as a feedback on the flow balance regarding the hydraulic capacity.

This work implements the above-mentioned models in a dynamic simulation program analyzing the behavior of the entire system under different conditions and functional configurations, as previously reported in [7].

On the basis of the users project requirements and according to defined parametric studies and initial assumptions, a possible sizing of the complete system and its three users (characterized by reversible actuators) has been attained in case of:

- users 2 and 3 with ramp generator acting on the command input,
- users 2 and 3 with reduced spool stroke acting in the aiding load conditions.

The ramp generator imposes a maximum growth rate (in absolute value) to the input command, so converting step into ramp commands.

The reduced spool stroke regards the actuation condition in which a defined user is generally affected by an aiding load and consists of the construction of the control valve spool and consists of the construction of the control valve spool having non symmetrical ends of travel, in order to perform a sort of braking action when the load aids the motion.

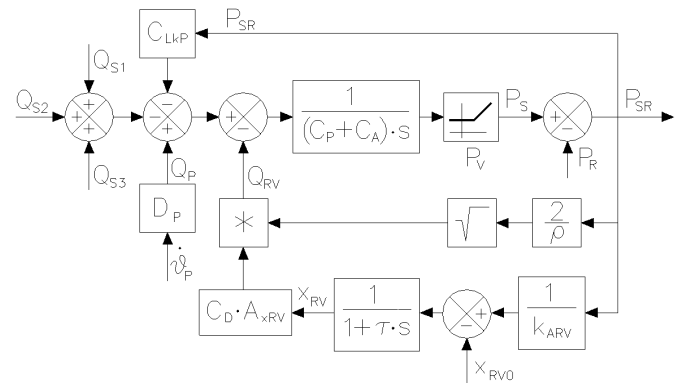

Figure 4. Schematic of the hydraulic system and related users.

V. COMPARISON BETWEEN THE CONFIGURATIONS BEHAVIORS

The operating conditions significant in the present analysis are characterized by aiding loads acting on users 2 and 3 and opposing on user 1.

In fact, Fig. 5-12 concern the above reported conditions, represented by the sequenced actuations of the users 2 and 3 with the following sequence of the input commands: at Time = 0 s, when the supply pressure P_S (28.9 MPa) in no flow condition reaches a stabilized value, the users 1 and 2 are respectively submitted to the commands Com1 (from 0 to 0.03 m) and Com2 (from 0.04 to 0 m), whereas at Time = 0.10 s the user 3 is submitted to the command Com3 (from 0.035 to 0 m). In the same instants of command input a step opposing load of 10 kN is applied to the user 1 and a step aiding load of 120 kN (Fig. 5-8) or 60 kN (Fig. 9-12) is applied to users 2 and 3.

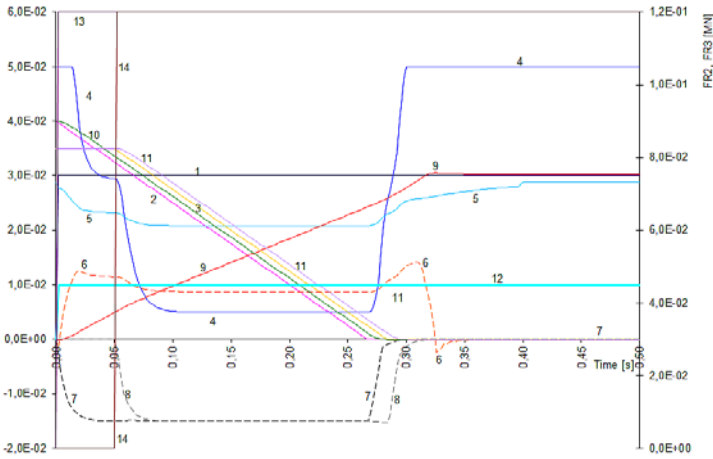

Figure 5. Actuation with users 2 and 3 equipped with a ramp generator.

N°	Name	N°	Name
1	Com ₁ [m]	8	DX _{J3} [10*m/s]
2	Com ₂ [m]	9	X _{J1} [10*m/s]
3	Com ₃ [m]	10	X _{J2} [10*m/s]
4	X _{RV} [dm]	11	X _{J3} [10*m/s]
5	P _S [GPa]	12	F _{R1} [MN]
6	DX _{J1} [10*m/s]	13	F _{R2} [MN]
7	DX _{J2} [10*m/s]	14	F _{R3} [MN]

Fig. 5 shows the case relating to the users 2 and 3 equipped with a ramp generator acting on the command input limiting the slope of the command input to a maximum value of 0.15 m/s.

By the comparison of this case with the simulation reported as Fig. 10 in [8], it can be noted that the employment of the ramp generator applied to the users 2 and 3 permits to correctly perform the actuations of the three users without the severe supply pressure drop shown the case of Fig. 10 in [8]. In fact the reduced actuation rate imposed to the users 2 and 3 prevents the malfunctioning of the user 1 caused by the high requested flow rate and by the consequent pressure drop.

Fig. 6 shows the case relating to the users 2 and 3 equipped with reduced spool stroke (83% of the stroke in opposing load condition) in the retraction mode, which is always characterized by aiding load.

By the comparison of this case with the simulation reported as Fig. 10 in [8] and with the case of previous Fig. 5, it can be noted that the problem reported in Fig. 10 in [8] is not completely removed, because the supply pressure drop is still present, having the consequence of supply pressure oscillations, pump cavitation and inability of the user 1 to perform the requested actuation. The problem is only reduced with respect to Fig. 10 in [8]. It must be noted that the malfunctioning (pump cavitation) encountered in case in Fig. 10 in [8] and Fig. 6 can severely compromise the airplane integrity, so being safety critical.

Fig. 7 shows the case relating to the users 2 and 3 equipped with reduced spool stroke (67% of the stroke in opposing load condition) in the retraction mode with aiding load. In this case the braking action performed by the users 2 and 3 servovalves is able to prevent any excessive supply pressure drop and consequent pump cavitation; the user 1 is characterized by a significant actuation rate reduction while user 2 and 3 are running without any actuation reversion. This operating condition is clearly more satisfying than the corresponding cases in Fig. 10 in [8] and Fig. 6, but the marked actuation rate reduction regarding the user 1 may compromise the correct aircraft controllability.

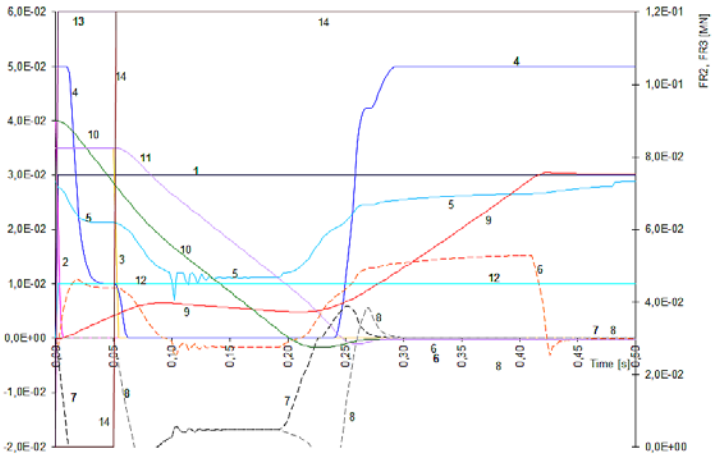

Figure 6. Actuation with users 2 and 3 equipped with reduced spool stroke (83% of the stroke in opposing load condition).

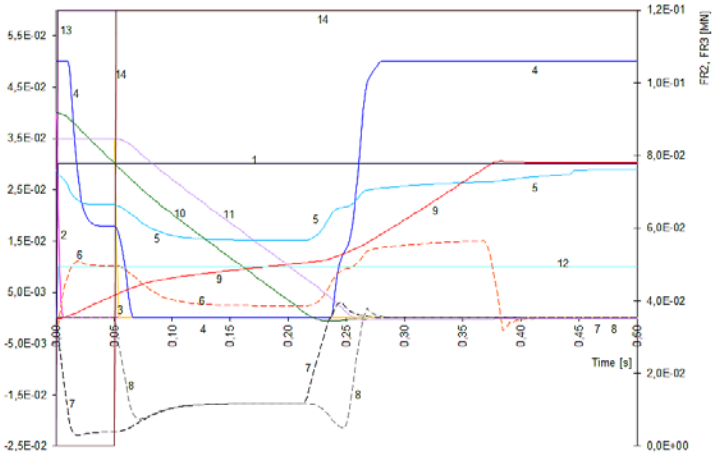

Figure 7. Actuation with users 2 and 3 equipped with reduced spool stroke (67% of the stroke in opposing load condition).

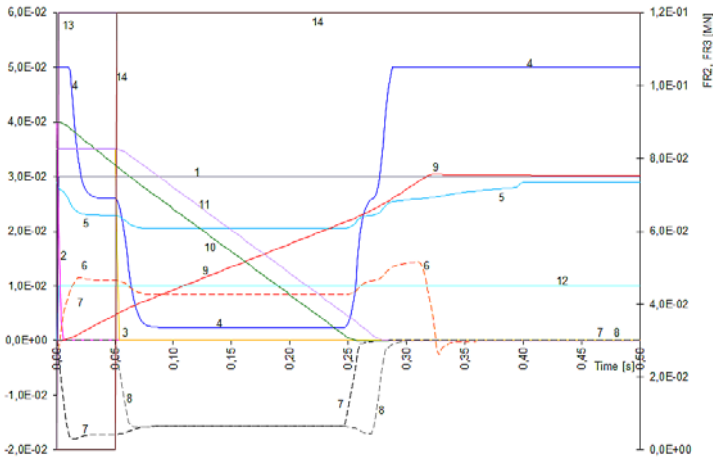

Figure 8. Actuation with users 2 and 3 equipped with reduced spool stroke (50% of the stroke in opposing load condition).

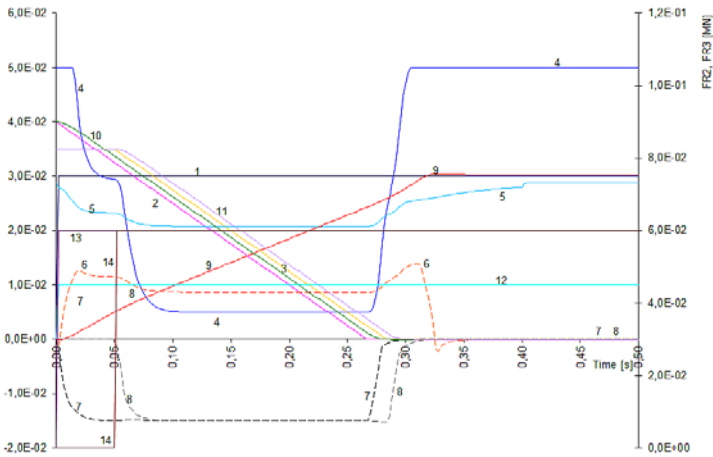

Figure 9. Actuation with users 2 and 3 equipped with a ramp generator and with loads of 60 kN.

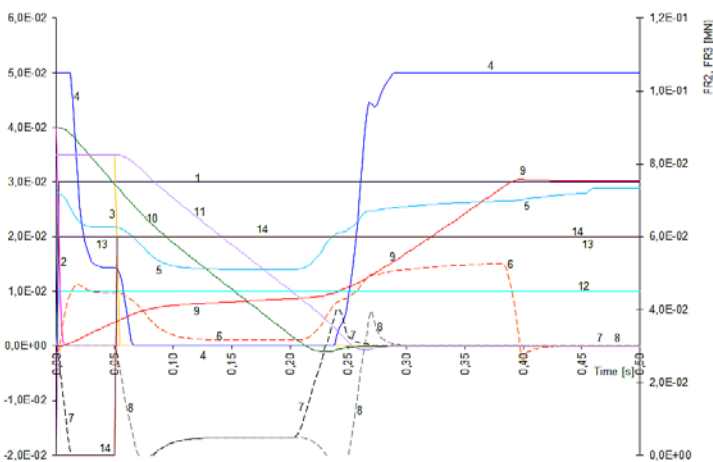

Figure 10. Actuation with users 2 and 3 equipped with reduced spool stroke (83% of the stroke in opposing load condition) and with loads of 60 kN.

Fig. 8 shows the case relating to the users 2 and 3 equipped with reduced spool stroke (50% of the stroke in opposing load condition) in the retraction mode with aiding load.

In this conditions the performance of the three users are maintained within the requested limits: in fact, nevertheless the slightly reduced actuation rate concerning the users 2 and 3, user 1 is able to perform correctly its travel, similarly to the case of Fig. 5, which is considered the reference behavior of the system. The technical solution considered in Fig. 8 (50% reduced spool stroke) is cheaper than this of Fig. 5 (ramp generator), retaining the same ability to solve the problem. Perhaps the reduced spool stroke solution could be considered always better than the ramp generator: the following considerations show the possible shortcomings of the reduced spool stroke solution in case of different load conditions.

Fig. 9 reports the case relating to the users 2 and 3 equipped with a ramp generator acting as in Fig. 5, but with loads of 60 kN applied to users 2 and 3. By the comparison of this case with the simulation reported in Fig. 5, it can be noted the effect of the ramp generator, which is able to maintain unaltered actuation speed independently of the applied load value. As before, the employment of the ramp generator permits to correctly perform the actuations of the three users without severe supply pressure drop.

Fig. 10 shows the case relating to the users 2 and 3 equipped with reduced spool stroke (83% of the stroke in opposing load condition) as the case of Fig. 6, but with loads of 60 kN applied to users 2 and 3. By the comparison of the two simulations, it can be noted the following: as a consequence of the reduced flow requested by the users 2 and 3, user 1 exhibits a positive value of the actuation rate, without any type of pump cavitation. Nevertheless, the user 1 actuation rate is unacceptably reduced if compared with the quite satisfactory case of Fig. 9.

Fig. 11 shows the case relating to the users 2 and 3 equipped with reduced spool stroke (67% of the stroke in opposing load condition) as the case of Fig. 7, but with loads of 60 kN applied to users 2 and 3. By the comparison of the two simulations, it can be noted the following: the flow requested by the users 2 and 3 in case of 60 kN is lower than in case of 120 kN, therefore user 1 exhibits a lower reduction of the actuation rate and the pump cavitation is completely avoided. The user 1 actuation rate is merely acceptably reduced if compared with the quite satisfactory case of Fig. 9.

Fig. 12 shows the case relating to the users 2 and 3 equipped with reduced spool stroke (50% of the stroke in opposing load condition) as the case of Fig. 8, but with loads of 60 kN applied to users 2 and 3; the further reduction of the requested flow produces the only marginal reduction of the user 1 actuation rate, preventing any pump cavitation. The user 1 actuation rate is quite acceptable if compared with the case of Fig. 9.

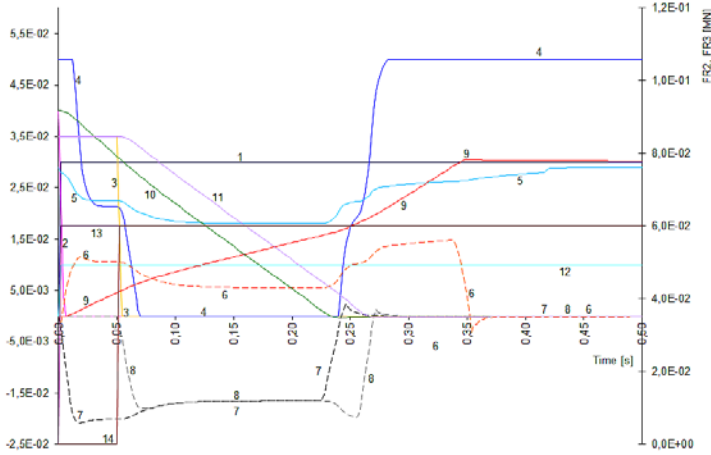

Figure 11. Actuation with users 2 and 3 equipped with reduced spool stroke (67% of the stroke in opposing load condition) and with loads of 60 kN.

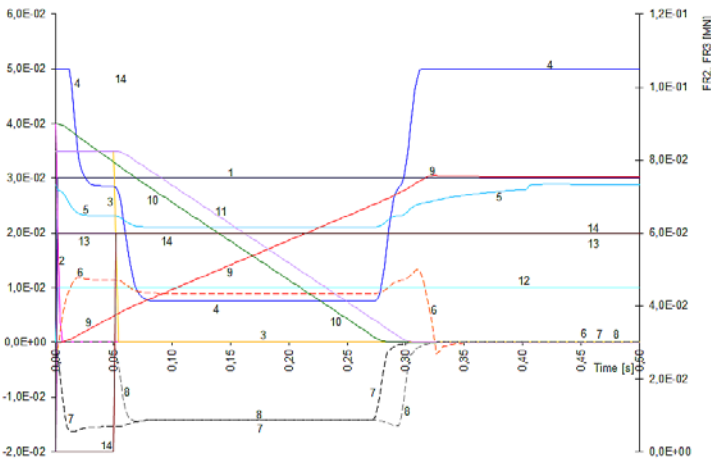

Figure 12. Actuation with users 2 and 3 equipped with reduced spool stroke (50% of the stroke in opposing load condition) and with loads of 60 kN.

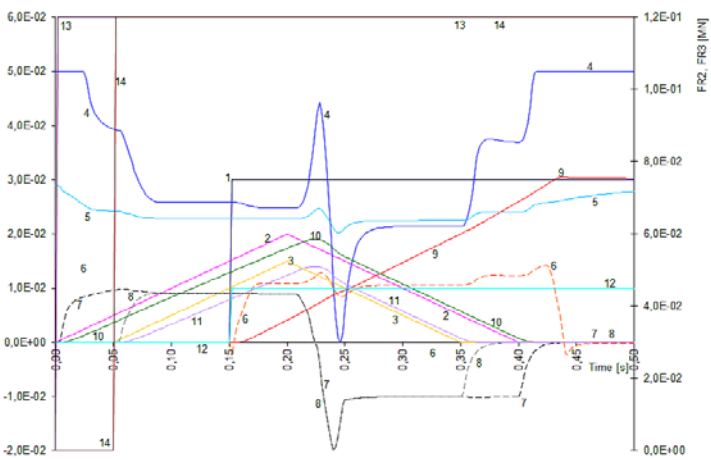

Figure 13. Actuation with users 2 and 3 equipped with a ramp generator – quick motion reversion commanded case.

Generally, it must be noted that the limitation of the spool stroke exhibits an advantage in the general behavior of the system: in fact the user 1 (intended as a primary flight control) is more and more insensitive to the load conditions of the users 2 and 3 when the above mentioned spool stroke is reduced. As a consequence, if the user 1 actuation time is reduced, the user 2 and 3 actuation times are increased, but this is not considered a shortcoming if the actuation rate imposed by ramp generator is believed as satisfactory.

Another operative condition significant for the present analysis is represented by the quick motion reversion commanded to the users 2 and 3 with the consequent opposing/aiding load condition. This condition, in which the user 1 is interested by an opposing load, is shown in Fig. 13-16 and is characterized by the following input sequence: at Time = 0 s, when the supply pressure P_s (28.9 MPa) in no flow condition reaches a stabilized value, the user 2 is submitted to the command Com2 (from 0 to 0.04 m) and to a step opposing load of 120 kN, whereas at Time = 0.05 s the user 3 is submitted to the command Com3 (from 0 to 0.035 m) and to a step opposing load of 120 kN. At Time = 0.15 s user 1 is submitted to the command Com1 (from 0 to 0.03 m) and to a step opposing load of 10 kN, retained till to the end of simulation. At Time = 0.20 s, when the commanded positions of 2 and 3 are not yet reached, an actuation rate reversion is commanded to user 2 and 3 (Com2 from 0.04 to 0 m and Com3 from 0.035 to 0 m) retaining the same load values, so performing aiding loads along the remaining portion of travel.

Fig. 13 shows the case relating to the users 2 and 3 equipped with a ramp generator acting on the command input limiting the slope of the command input to a maximum value of 0.15 m/s. By the comparison of this case with the Fig. 5, it can be confirmed that the employment of the ramp generator permits to correctly perform the actuations without the severe supply pressure drop, preventing any malfunctioning.

Fig. 14 shows the case relating to the users 2 and 3 equipped with reduced spool stroke (83% of the stroke in opposing load condition) in the same case reported in Fig. 13. By the comparison of this case with the simulation reported as Fig. 10 in [8] and with the case of previous Fig. 13, it can be noted that the problem reported in Fig. 10 in [8] is not completely removed, because the supply pressure drop is still present during the aiding load run, having the consequence of supply pressure oscillations, pump cavitation and inability of the user 1 to perform the requested actuation.

Fig. 15 shows the case relating to the users 2 and 3 equipped with reduced spool stroke (67% of the stroke in opposing load condition) in the same case reported in Figs. 13 and 14. In this case the braking action performed by the users 2 and 3 servovalves is able to prevent any excessive supply pressure drop and consequent pump cavitation during the aiding load run; the user 1 is characterized by a significant actuation rate reduction while user 2 and 3 are running without any actuation reversion.

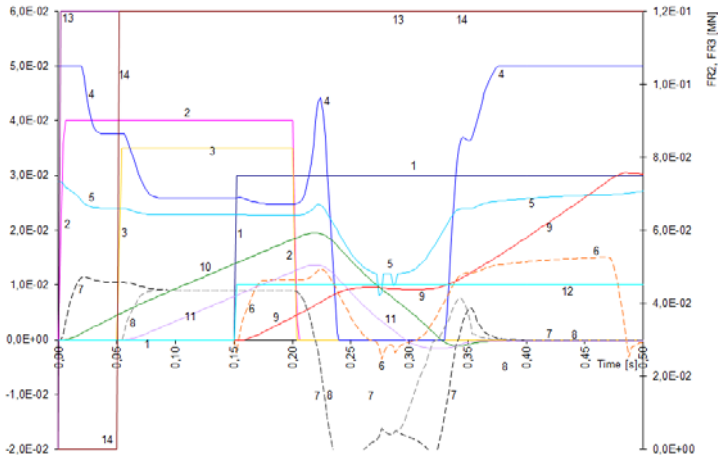

Figure 14. Actuation with users 2 and 3 equipped with reduced spool stroke (83% of the stroke in opposing) – quick motion reversion commanded.

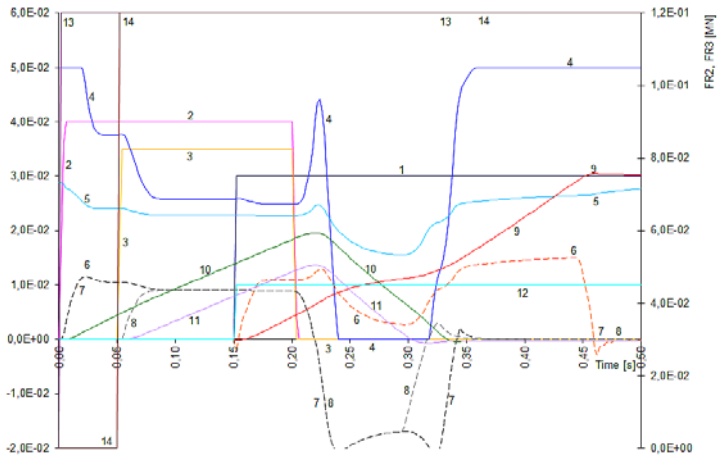

Figure 15. Actuation with users 2 and 3 equipped with reduced spool stroke (67% of the stroke in opposing) – quick motion reversion commanded.

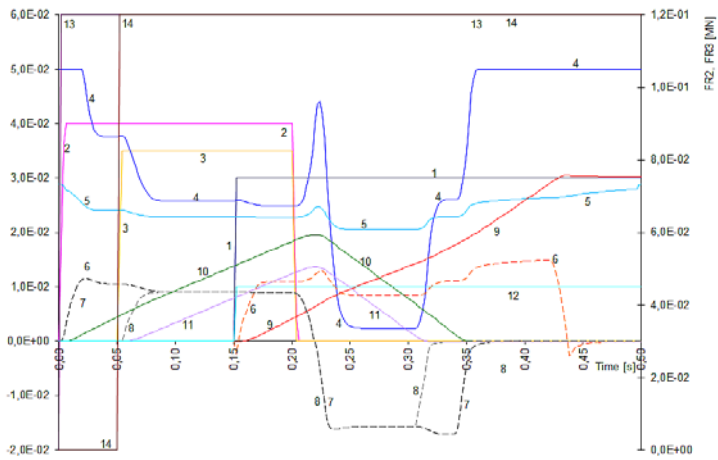

Figure 16. Actuation with users 2 and 3 equipped with reduced spool stroke (50% of the stroke in opposing) – quick motion reversion commanded.

This operating condition is clearly more satisfying than the corresponding cases in Fig. 10 in [8] and Fig. 14, but the marked actuation rate reduction regarding the user 1 may compromise the correct aircraft controllability.

Fig. 16 shows the case relating to the users 2 and 3 equipped with reduced spool stroke (50% of the stroke in opposing load condition) in the same case reported in Fig. 13-15. In these conditions the performance of the three users are maintained within the requested limits: in fact, nevertheless the slightly reduced actuation rate during the aiding load run of users 2 and 3, the user 1 is able to perform correctly its travel, similarly to the case of Fig. 13, which is considered the reference behavior of the system.

The technical solution considered in Fig. 16 (50% reduced spool stroke) is cheaper than this of Fig. 13 (ramp generator), retaining the same ability to solve the problem.

Therefore the reduced spool stroke can be considered always the better solution with respect to the ramp generator, if the cases concerning the reduced aiding loads applied to the users 2 and 3 are neglected.

VI. CONCLUSIONS

By the survey of the above reported simulations, referred to the analysis of the dynamic behavior of different system configurations in similar operative conditions, it is deduced as apparently minor design options regarding the users architecture (such as the employment of command ramp generators or control servovalves having reduced spool stroke acting in the aiding load conditions) may play a significant role in the behavior of the entire system, affecting on its sizing, especially with regard to the pump. It must be noted that the solution employing the reduced spool stroke is cheaper than the ramp generator, nevertheless some shortcomings may be involved in its use, because the aiding load value greatly affects the actuation speed; so, if the spool stroke reduction is designed according to the high load requirements, in case of lower loads the actuation speed reduction may be excessive. This problem is quite absolutely absent in case of ramp generator.

VII. NOMENCLATURE

- A_J Jack working area
- A_{SV} Servovalve second stage driving area
- A_{xRV} Ratio between passageway area and flapper displacement of the pressure relief valve
- C_A Hydraulic accumulator capacity
- C_D Generic discharge coefficient
- C_{Lk} Leakage coefficient of the SV-actuator assembly
- C_{LkP} Pump leakage coefficient

$Com_{1,2,3} = \theta_C$	User 1,2,3 input command
C_P	Pipes hydraulic capacity
C_J	Jack damping coefficient
D_P	Pump displacement [m ³ /rad]
$DX_{J1,2,3} = d\theta_j/dt$	User 1,2,3 actuation rate
e_{IM}	Integrator output maximum value
$FR_{1,2,3} = F_R$	User 1,2,3 external load
G_{AD}	Position derivative gain
G_{AI}	Position integrative gain
G_{AP}	Position proportional gain
G_{AS}	Speed loop gain
G_M	Servo valve torque gain
G_{PQ}	Servo valve second stage pressure to flow gain ratio
G_{QF}	Servo valve first stage flow gain in reference conditions ($P_{SR} = P_{SR0}$)
I	Servo valve input current
I_H	Magnetic hysteresis cycle semi amplitude of servo valve torque motor, considered in terms of equivalent current
I_M	Servo valve current in saturation conditions
k_{ARV}	Ratio between pressure relief valve spring stiffness and shutter area
K_F	Servo valve first stage elastic hinge stiffness
K_{SF}	Servo valve internal feedback spring stiffness
M_J	Mass of the actuator-user assembly
P_R	Hydraulic system return pressure
$PS = P_S$	Supply pressure
P_{SR}	Differential supply to return pressure
P_{SR0}	Reference value of P_{SR}
P_V	Hydraulic oil vapor pressure
P_{12}	Differential pressure acting on the actuator
Q_P	Pump flow
Q_{RV}	Pressure relief valve flow
$Q_{S1,2,3}$	Users 1,2,3 requested flows (respectively)
X_F	Servo valve first stage position
X_{FM}	Servo valve first stage end of travel
$XR_V = X_{RV}$	Pressure relief valve shutter position
X_{RV0}	Ratio between pressure relief valve spring preload to stiffness
X_S	Servo valve second stage position
X_{SM}	Servo valve second stage end of travel
X_{SS}	X_s value at which P_{12} reaches saturation condition
$X_{J1,2,3} = \theta_j$	User 1,2,3 actuator position
$d^2\theta_j/dt^2$	Actuator acceleration
$d\theta_p/dt$	Pump angular rate
σ_{nF}	Servo valve first stage undamped circular frequency
ζ_F	Servo valve first stage damping ratio
ρ	Oil density
τ	Pressure relief valve time constant

REFERENCES

- [1] G. Jacazio, L. Borello, G. Villero, "Secondary flight controls: mechanical failures of transmission lines and related asymmetry problems", 19th ICAS Congress, Anaheim, California, U.S.A., 18-23 September, 1994.
- [2] L. Borello, G. Villero, E. D'Onofrio, "A Critical Comparison between Different Methods of Flap Systems Actuation Speed Limitation", 20th I.C.A.S. Congress, Sorrento, Italy, September 1996.
- [3] L. Borello, G. Villero, "Mechanical Failures of Flap Control Systems and Related Monitoring Techniques", 21st I.C.A.S. Congress, Melbourne, Australia, September 1998.
- [4] L. Borello, G. Villero, "Flap control systems actuators: mathematical and computational model for dynamic simulation", European Congress on Computational Methods in Applied Sciences and Engineering, ECCOMAS 2000, Barcelona, Spain, 11-14 September 2000.
- [5] L. Borello, M. D. L. Dalla Vedova, "Load dependent coulomb friction: a mathematical and computational model for dynamic simulation in mechanical and aeronautical fields", International Journal of Mechanics and Control (JoMaC), Vol. 07, No. 01, July 2006, pagg. 19-30.
- [6] L. Borello, M. Dalla Vedova, "A dry friction model and robust computational algorithm for reversible or irreversible motion transmission", International Journal of Mechanics and Control (JoMaC), Vol. 13, No. 02, December 2012, pagg. 37-48, ISSN: 1590-8844
- [7] L. Borello, G. Villero, M. Dalla Vedova, "Redundant hydraulic secondary flight control systems behavior in failure conditions", Journal of Mechanics Engineering and Automation, Vol. 03, No. 08, August 2013, pagg. 499-506, ISSN: 2159-5275
- [8] L. Borello, G. Villero, M. Dalla Vedova, "Interaction Problems Between Users in the Design of Hydraulic System", GSTF Journal on Aviation Tecnology (JAT), Vol. 01, No. 01, 2014.



Lorenzo Borello received the M.Sc. from the Politecnico di Torino in 1973. He is a retired full professor and continues to cooperate with other researchers of the Department of Mechanics and Aerospace Engineering. His research activity is mainly focused on aeronautical systems engineering and, in particular, is dedicated to design, analysis and numerical simulation of on board systems, study of secondary flight control system and conception of related monitoring strategies and developing diagnostic algorithms for aerospace servomechanism and flight controls.



Giuseppe Villero received the M.Sc. from the Politecnico di Torino in 1974. He is an assistant professor at the Mechanical and Aerospace Engineering Department of Politecnico di Torino, that joined in 1982. Since 2003 he is also an aggregate professor in the same Department where he teaches aerospace structural engineering. His research activity is mainly focused on the aeronautical systems engineering and, in particular, is dedicated to design, analysis and numerical simulation of on board systems, and conception of related monitoring strategies.



Matteo D. L. Dalla Vedova received the M.Sc. and the Ph.D. from the Politecnico di Torino in 2003 and 2007, respectively. He is currently assistant researcher at the Department of Mechanics and Aerospace Engineering. His research activity is mainly focused on the aeronautical systems engineering and, in particular, is dedicated to design, analysis and numerical simulation of on board systems, study of secondary flight control system and conception of related monitoring strategies and developing of prognostic algorithms for aerospace servomechanism.