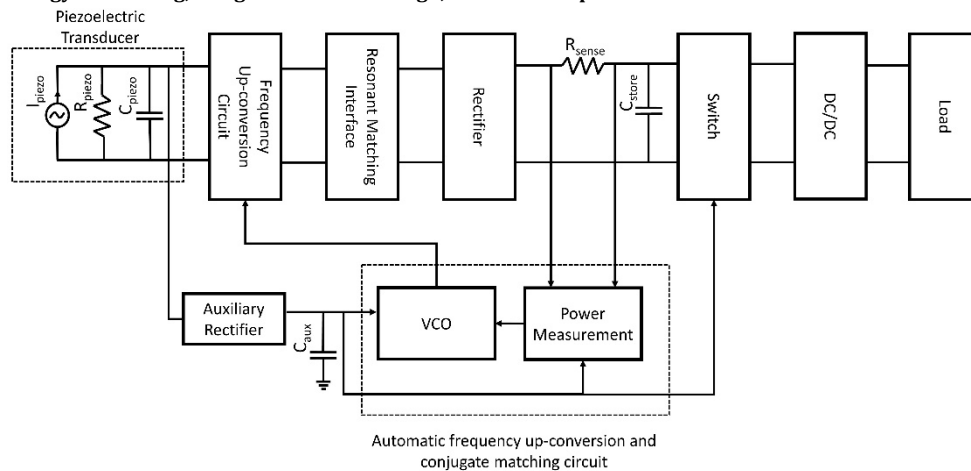

Master Thesis Proposal 2018

Dynamic frequency up-conversion technique for piezoelectric energy harvester

Keywords: Energy Harvesting, Integrated Circuit Design, Low Power Optimization

**Background:**

Distributed self-powered sensors require advanced technology to efficiently harvest the power available from the surrounding environment. Piezoelectric energy harvesting is a promising technology commonly adopted to transduce mechanical vibrations into an AC signal, which cannot be used directly to power electronic devices. Hence, a harvesting interface has to be designed to rectify, store and regulate the available energy. The output impedance of piezoelectric transducers is mainly capacitive over a wide frequency band. To maximize the power conversion efficiency for multiple excitation frequencies, the harvesting interface should match dynamically the transducer impedance.

System Overview:

The thesis activity is part of a research project aimed to design an Integrated Circuit (IC) to efficiently scavenge energy from a random low-power input signal generated by a vibrating piezoelectric transducer. The harvesting architecture is based on an automatic frequency up-conversion technique [1,2], which will match dynamically the output impedance of the piezoelectric transducer by shifting the vibrational frequency of the piezoelectric element up to the resonant frequency of the harvesting interface. A switched transformer will be used as active component to implement the up-conversion technique. To control dynamically the switching frequency of the transformer, a feedback loop with on-chip power measurements and a voltage-controlled oscillator will be adopted. The feedback loop keeps the harvesting interface at the maximum output power point independently from the mechanical excitation frequency.

Tasks:

The student with background in microelectronics will be involved in the design of the IC for the harvesting interface. The research project comprises: (A) Circuit schematic optimization; (B) Physical layout design; (C) Parasitic extraction and validation of the physical design.

Partners and funding:

The research activity is funded by the National Natural Science Foundation of China (No. 61531008) and by the industrial partner Sensovann AS, which will offer a monthly compensation of 300€ to the candidate. The activity will be conducted in cooperation with researchers at University of Southeast Norway (USN), Politecnico di Torino, Chongqing Technology and Business University (CTBU) and Shanghai Jiaotong University (SJTU).

Outcome:

A good thesis project will encourage the candidate to join the Ph.D. program by continuing the research work on piezoelectric energy harvesting. A good master student will have the possibility of one publication on an IEEE conference or journal paper and will have the opportunity to visit CTBU in China.

Supervisors: Prof. Tao Dong (tao.dong@usn.no) and Prof. Mario R. Casu (mario.casu@polito.it).

[1] P. Li, et al. "An upconversion management circuit for low-frequency vibrating energy harvesting," IEEE Transactions on Industrial Electronics.
[2] P. Li et al, "A magnetolectric composite energy harvester and power management circuit," IEEE Transactions on Industrial Electronics.